

600V 0.5A Switching Current Buck PFM LED Constant Current Driver

XL5003

Features

- Operate from a rectified 85V~265V AC mains supply.
- 0.2V current sense voltage reference.
- Directly drive 2~8 series 1W LED.
- Excellent line and load regulation.
- Internal optimize power HV-MOSFET.
- Built in thermal shutdown function.
- Built in UVLO function.
- Built in current limiting function.
- Built in LED open & short protection.
- Built in soft-start circuit.
- Support without electrolytic capacitor System solution.
- Available in SOIC-8 package.
- PF > 0.9 (Power Factor) with suitable External components.

Applications

- E27, GU10, GU5.3, B22 lamp device
- LED daylight lamp
- LED Lighting & LED LAMP
- General purpose lighting

General Description

The XL5003 is a monolithic high voltage switching regulator with PFM that is specifically designed to operate from a rectified 85V~265V AC mains supply.

The XL5003 is a high efficiency LED driver switching regulator. The LED string is driven at DC constant current rather than constant voltage, thus providing constant current output and enhanced reliability.



SOIC-8

Figure1. Package Type of XL5003

600V 0.5A Switching Current Buck PFM LED Constant Current Driver	XL5003
---	---------------

Pin Configurations

NC	1	8	VSS
VDD	2	7	VSS
XL5003			
IS	3	6	VIN
SW	4	5	VIN

Figure2. Pin Configuration of XL5003 (Top View)

Table 1 Pin Description

Pin Number	Pin Name	Description
1	NC	No Connected.
2	VDD	The chip supply voltage.
3	IS	Current Sense Pin. (The current sense voltage is 0.2V)
4	SW	Output Switching Pin
5 , 6	VIN	Input high voltage Pin. (Operation voltage 100V~400V)
7 , 8	VSS	The chip reference ground.

Function Block

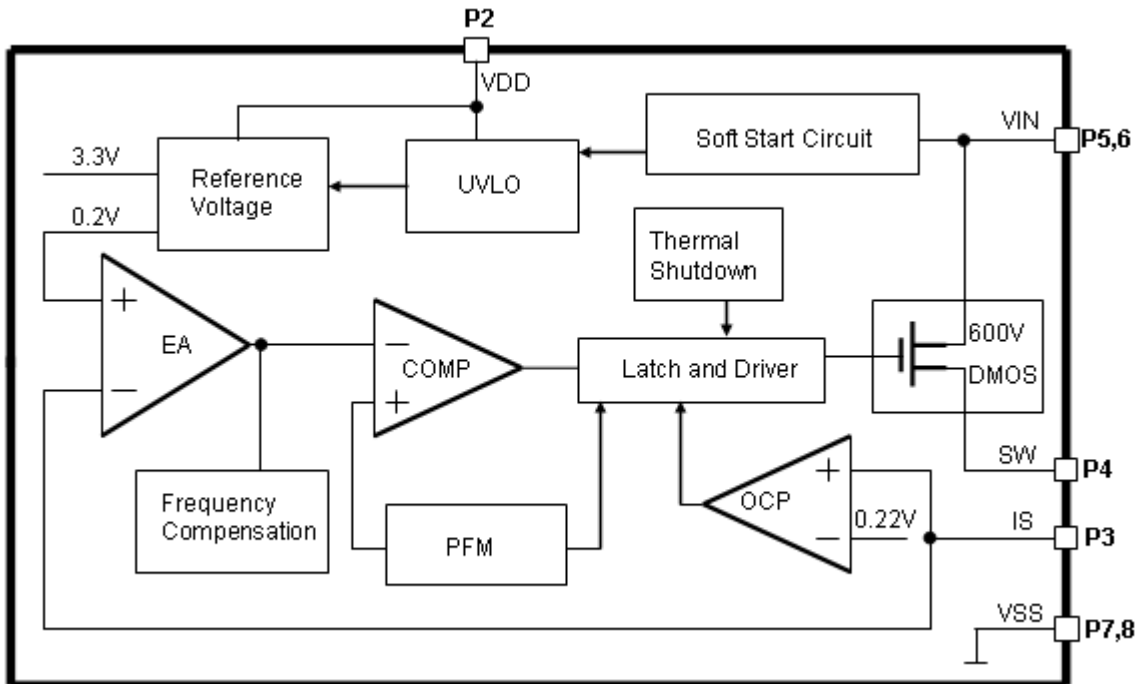
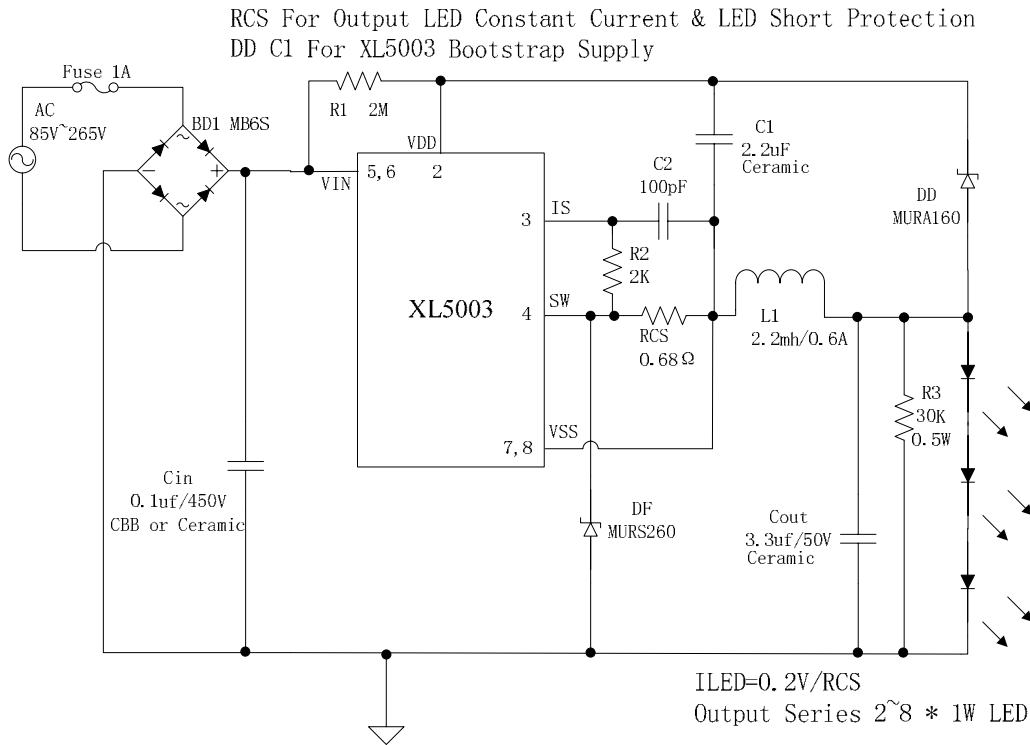

Figure3. Function Block Diagram of XL5003

600V 0.5A Switching Current Buck PFM LED Constant Current Driver XL5003

Typical application circuit



- [1] Input AC 85V~265V Mains Supply.
- [2] Output Constant Current Drive Series 2~8 * 1W LED.
- [3] Support Output LED Open & Short Protection.
- [4] Support Without Electrolytic Capacitor Solution For High Reliability & High Performance.

Figure4. XL5003 Typical Application (Mains supply 2W~8W LED saving energy lamp)

600V 0.5A Switching Current Buck PFM LED Constant Current Driver	XL5003
--	--------

Ordering Information

Order Information	Marking ID	Package Type	Packing Type Supplied As
XL5003E1	XL5003E1	SOP-8L	2500 Units on Tape & Reel

XLSEMI Pb-free products, as designated with “E1” suffix in the par number, are RoHS compliant.

Absolute Maximum Ratings (Note1)

Parameter	Symbol	Value	Unit
Input Voltage	V_{in}	-0.3 to 600	V
Power Dissipation	P_D	Internally limited	mW
Thermal Resistance (SOP-8L) (Junction to Ambient, No Heatsink, Free Air)	R_{JA}	100	°C/W
Operating Junction Temperature	T_J	-40 to 125	°C
Storage Temperature	T_{STG}	-65 to 150	°C
Lead Temperature (Soldering, 10 sec)	T_{LEAD}	260	°C
ESD (HBM)		3000	V

Note1: Stresses greater than those listed under Maximum Ratings may cause permanent damage to the device. This is a stress rating only and functional operation of the device at these or any other conditions above those indicated in the operation is not implied. Exposure to absolute maximum rating conditions for extended periods may affect reliability.

600V 0.5A Switching Current Buck PFM LED Constant Current Driver	XL5003
--	--------

XL5003 Electrical Characteristics

T_a = 25 °C; unless otherwise specified. Reference test circuit figure5

Symbol	Parameter	Test Condition	Min.	Typ.	Max.	Unit
VIS	IS Voltage	VAC = 220V, I _{led} =0.3A, P _{out} =2W ~ 8W	190	200	210	mV
Efficiency	η	VAC=110V, I _{led} =0.3A, P _{out} =8W	-	83.46	-	%
Efficiency	η	VAC=220V, I _{led} =0.3A, P _{out} =8W	-	83.22	-	%

Electrical Characteristics (DC Parameters)

Parameters	Symbol	Test Condition	Min.	Typ.	Max.	Unit
Input Operation Voltage	V _{IN}		100		400	V
Chip Supply Voltage	V _{DD}		10		40	V
Quiescent Supply Current	I _q	Figure5, VAC=220V I _{led} =0		0.15	0.3	mA
Switching Frequency	F _{osc}	Figure5 (6*1W) VAC=220V	30.1	37.6	45.1	KHz
Max. Duty Cycle	D _{MAX}			25		%
VDMOS Drain-Source Breakdown Voltage	V _{BRDS}	V _{GS} =0V, I _{DS} =250uA	600			V
VDMOS Drain-Source on resistor	R _{DS(on)}	I _{DS} =0.5A, V _{GS} =10V		8	10	Ohm
Thermal Shutdown	OTP	T _j		165		°C
Thermal Shutdown Window				25		°C

600V 0.5A Switching Current Buck PFM LED Constant Current Driver XL5003

[1] Typical application circuit without electrolytic capacitor (2W ~ 8W)

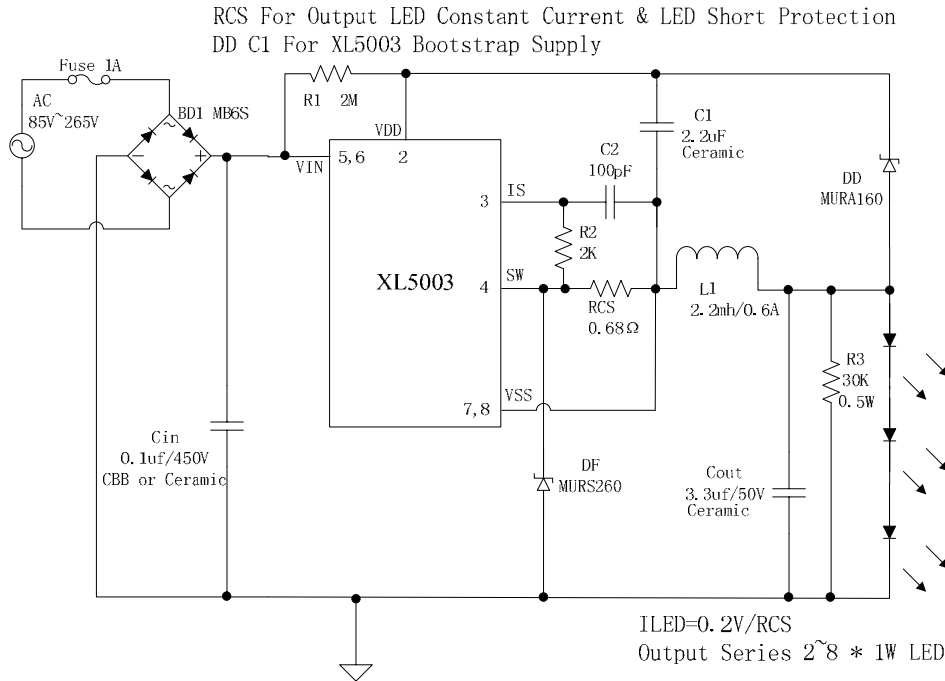

- [1] Input AC 85V~265V Mains Supply.
- [2] Output Constant Current Drive Series 2~8 * 1W LED.
- [3] Support Output LED Open & Short Protection.
- [4] Support Without Electrolytic Capacitor Solution For High Reliability & High Performance.

Figure5. XL5003 System Application for AC LED LAMP (2W ~ 8W)

VIN=110Vac						
1W LED Series	Pin(W)	PF	Vout (V)	Iout (mA)	Fosc(KHz)	EF(%)
2	2.6	0.391	6.23	287	18.07	68.77
3	3.6	0.450	9.23	285	23.81	73.07
4	4.5	0.511	12.33	282	28.99	77.27
5	5.4	0.574	15.48	278	34.42	79.69
6	6.2	0.607	18.47	273	37.59	81.33
7	7.0	0.648	21.49	269	41.05	82.58
8	7.8	0.672	24.66	264	48.38	83.46
VIN=220Vac						
1W LED Series	Pin(W)	PF	Vout (V)	Iout (mA)	Fosc(KHz)	EF(%)
2	3.0	0.370	6.27	311	17.50	65.00
3	4.0	0.412	9.30	308	21.40	71.61
4	5.1	0.476	12.30	308	26.91	74.28
5	6.1	0.462	15.62	306	32.74	78.36
6	7.1	0.449	18.68	305	37.59	80.25
7	8.0	0.485	21.83	302	38.89	82.41
8	9.0	0.518	25.05	299	45.81	83.22

600V 0.5A Switching Current Buck PFM LED Constant Current Driver XL5003

[2] Typical application circuit with PFC (2W ~ 8W)

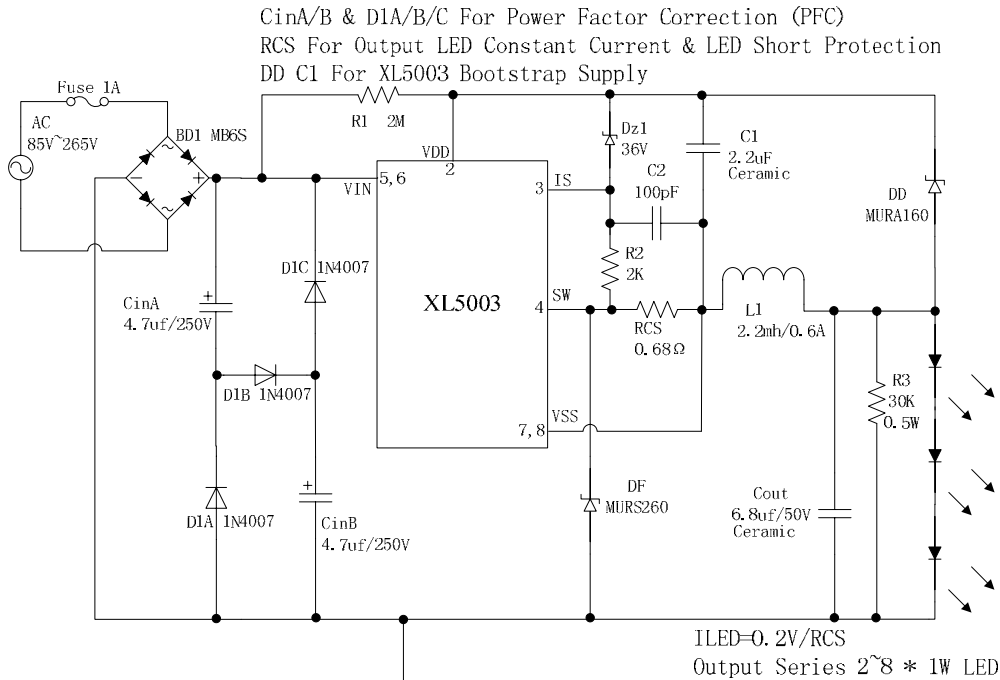

- [1] Input AC 85V~265V Mains Supply.
- [2] Output Constant Current Drive Series 2~8 * 1W LED.
- [3] Support Output LED Open & Short Protection.

Figure6. XL5003 System Application for AC LED LAMP (2W ~ 8W)

VIN=110Vac						
1W LED Series	Pin(W)	PF	Vout(V)	Iout(mA)	Fosc(KHz)	EF(%)
2	2.9	0.906	6.53	308	18	69.35
3	4.0	0.891	9.84	306	25	75.28
4	5.2	0.896	13.10	304	30	76.58
5	6.4	0.876	16.36	302	36	77.20
6	7.5	0.842	19.75	301	41	79.26
7	8.6	0.819	23.01	300	46	80.27
8	9.8	0.795	26.32	298	50	80.03
VIN=220Vac						
1W LED Series	Pin(W)	PF	Vout(V)	Iout(mA)	Fosc(KHz)	EF(%)
2	3.2	0.914	6.59	329	17	67.75
3	4.4	0.880	9.95	328	24	74.17
4	5.6	0.888	13.24	327	30	77.31
5	6.7	0.870	16.53	326	35	80.43
6	8.0	0.866	19.93	324	40	80.72
7	9.0	0.883	23.23	322	45	83.11
8	10.2	0.894	26.58	320	50	83.39

Package Information

SOP8 Package Mechanical Dimensions

SOIC-8

Unit: mm(inch)

